

# 336F XE

Hydraulic Excavator



## Engine

Engine Model	Cat® C9.3 ACERT™	
Net Power – SAE J1349	226 kW	303 hp

## Drive

Maximum Travel Speed	4.8 km/h	3 mph
Maximum Drawbar Pull	294 kN	66,093 lbf

## Weights

Minimum Operating Weight	37 100 kg	81,800 lb
Maximum Operating Weight	40 300 kg	88,800 lb



## Introduction

The 336F XE is the latest machine from Caterpillar that will significantly lower your owning and operating costs. Built with our proven hydraulic hybrid system, this excavator will cut your fuel consumption by up to 20% compared to our standard 336F – a market leader in and of itself for high efficiency.

Unlike models from other manufacturers, the 336F XE is loaded with additional technology that will help improve your bottom line even more. Features like time-tested Cat Grade Control and the new Cat Production Measurement System come standard on this machine – all to help you easily do work more quickly and efficiently.

So if you are looking for the absolute maximum level of productivity and efficiency from a 36-ton machine, look no further than the 336F XE. It will make you more money than any other brand bar none.

## Contents

Equipping Every Customer For Success .....	4
Hydraulics .....	6
Integrated Technologies .....	8
Engine .....	10
Operator Station .....	12
Structures & Undercarriage .....	13
Attachments .....	14
Front Linkage .....	16
Serviceability .....	17
Safety .....	18
Complete Customer Care .....	19
Sustainability .....	20
Specifications .....	21
Standard and Optional Equipment .....	35







**CAT**

**336F**

LXE

HYBRID

GRADE CONTROL



# Equipping Every Customer For Success

Building products just for you and your type of work.







Understanding your needs and requirements leads us to developing innovative products – products that help you win in a competitive environment. The 336F XE with hydraulic hybrid technology is the latest example of such an innovative product. This excavator is built for those of you who work machines long and hard and need the absolute highest level of productivity. When you see XE on a Cat machine, you can count on it being the most technologically advanced, fuel-efficient machine capable of working in all applications and material types.

Caterpillar also offers a traditional 336F model. This machine is built for those of you who also get paid by the job and are looking for a high level of productivity. Even though it isn't equipped with hydraulic hybrid technology, the 336F provides excellent fuel efficiency and productivity compared to competitive offerings.

So when you think of XE, think of the following attributes:

- Reliable, durable, and rebuildable
- Low cost per unit of work
- Breakthrough and innovative
- Maximum efficiency

When you think of the traditional model, think of these attributes:

- Reliable, durable, and rebuildable
- Low cost per unit of work
- Proven
- Highly efficient

No matter which model you choose, if it has the Cat brand on it, you can depend on it being a quality-made machine backed by the world's finest product support.

# Hydraulics

The more it works, the more you save.

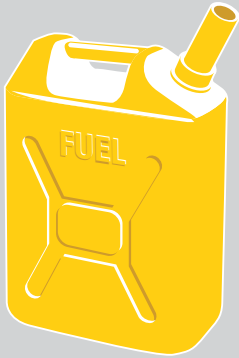

Up to  
**20%**  
less fuel consumption  
than 336F – the fuel  
economy and performance  
leader in its size class



- 1 – Hydraulic Hybrid Swing System
- 2 – Electronic Standardized Programmable (ESP) Pump
- 3 – Adaptive Control System (ACS) Valve



The 336F XE uses three building block technologies to deliver outstanding fuel savings and performance for you:

- The Cat Electronic Standardized Programmable (ESP) pump smoothly transitions between the hydraulic hybrid power sources, engine, and accumulator to conserve fuel.
- The Cat Adaptive Control System (ACS) valve optimizes performance by intelligently managing restrictions and flows to control machine motion.
- Instead of wasting kinetic energy during swing braking, the Cat Hydraulic Hybrid Swing System pressurizes the accumulator to stop the machine and then uses that pressure when needed to accelerate the machine later.

Bottom line: The hydraulic hybrid system is a simple, reliable, and cost-effective solution that will help you significantly reduce your cost per ton.

### **Our Smart Valve Is Smart For You**

The 336F L XE's hydraulic hybrid system is unlike hybrid systems available from any other heavy equipment manufacturer in business today. The key ingredient is the ACS valve, which you can find only on the Cat brand.

Think of the ACS valve as the "brain" of the system – one that independently controls machine functions and directs hydraulic energy where you need it precisely when you need it. Because the ACS valve is fully integrated with the pump and hybrid system, you will experience the same extraordinary control, hydraulic power, and lift capacity that you get from our traditional high-production machines with the added benefit of dramatically reduced fuel consumption. That's why we are now offering the valve on our larger machines like the 374F and 390F.

Smart valve. Smart machine. Simply a smart investment for your business.





# Integrated Technologies

Make your work easier and more efficient.

### PAYLOAD Technologies

Payload technologies accurately measure material being loaded or hauled. Payload data is shared with operators in real time to improve productivity, reduce overloading, and record progress.

### Cat Production Measurement

Cat Production Measurement brings payload weighing to the cab, enabling operators to weigh loads “on the go.” Loads are weighed as the boom swings. Operators can view load weights on the integrated display and know precisely how much material is in the bucket and when trucks are filled to target payload. Instant feedback gives operators the confidence to work more effectively, maximizing the potential of the entire fleet. Site managers can wirelessly access data via the VisionLink® web portal to measure production and monitor efficiency.



### LINK Technologies

LINK technologies like Product Link™ are deeply integrated into your machine and wirelessly communicate key information, including location, hours, fuel usage, idle time, and event codes.

### Product Link/VisionLink

Easy access to Product Link data via the online VisionLink user interface can help you see how your machine or fleet is performing. You can use this information to make timely, fact-based decisions that can boost job site efficiency and productivity and lower costs.



## GRADE Technologies

Grade technologies combine digital design data and in-cab guidance to help you reach target grade quickly and accurately with minimal staking and checking. That means you'll be more productive, complete jobs faster in fewer passes, and use less fuel for a lower cost.

### Cat Grade Control Depth And Slope

The factory-integrated Cat Grade Control system delivers 2D bucket tip elevation guidance to the cab to help operators create precise planes and slopes with ease. Real-time bucket tip elevation guidance on the easy-to-read standard cab monitor indicates how much to cut or fill. Fast response sensors deliver immediate feedback. Integrated joystick buttons help operators make quick adjustments to maintain consistent, quality grades. Built-in alerts can be set to warn the operator if the linkage or bucket approaches a predefined elevation or depth like when working in areas with low ceilings or digging near water lines. Staking and checking is minimized, which reduces ground crews and enhances job site safety. The system works best in simple 2D applications such as digging basements or grading steep embankments. You can easily upgrade to AccuGrade™ when 3D control is required.

### Cat AccuGrade

The dealer-installed AccuGrade system provides 3D guidance for making complex cuts and contours, eliminating the need for staking and checking. A dedicated monitor displays a digital design plan with 3D bucket tip positioning and elevation guidance, indicating precisely where to work and how much to cut or fill. The plug-and-play capability on the 336F XE simplifies upgrading. Choose from satellite (GNSS) control for large projects with complex designs or total station (UTS) systems in areas with limited reception.

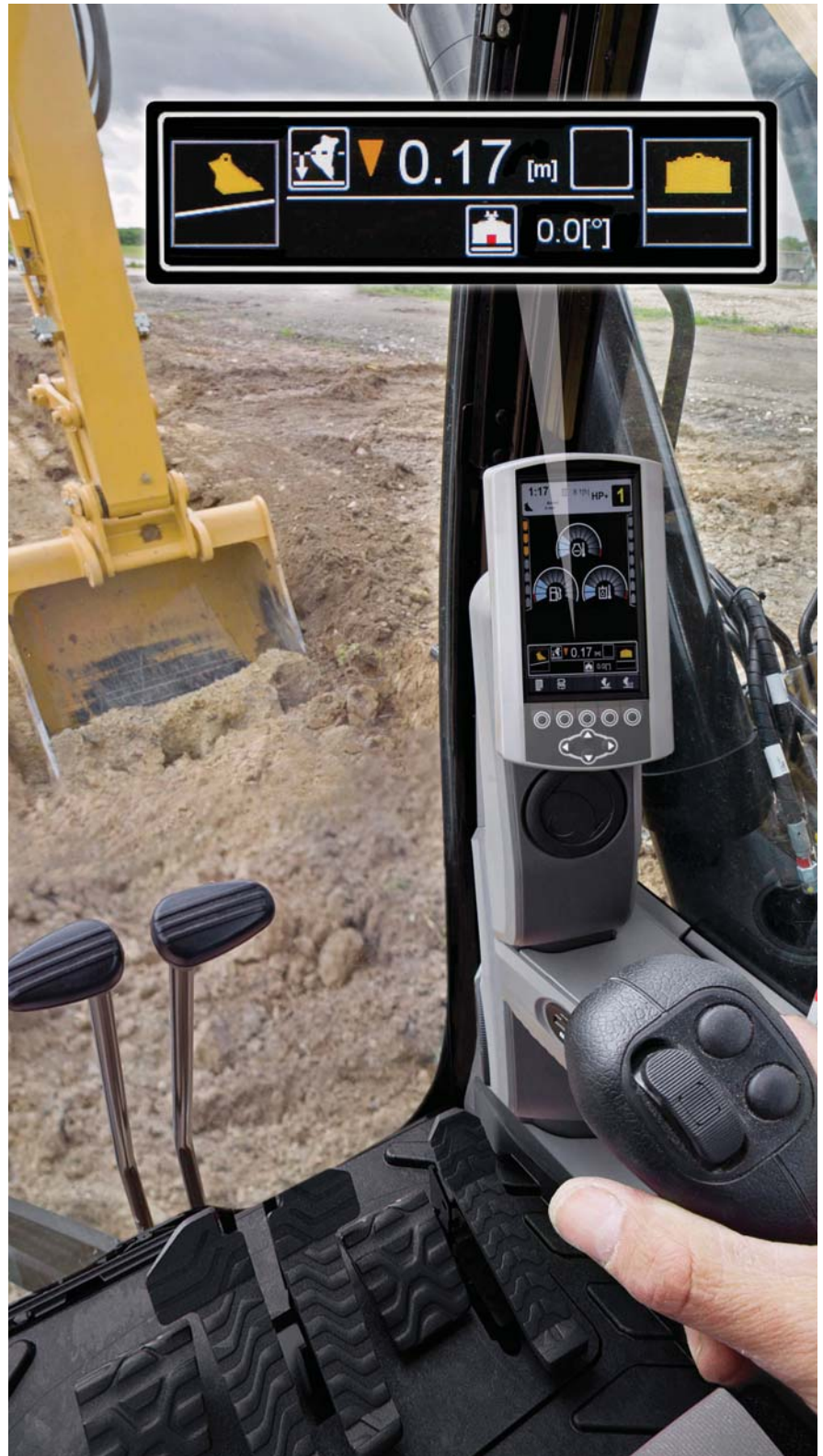



# Engine

Efficient and reliable performance you can count on.

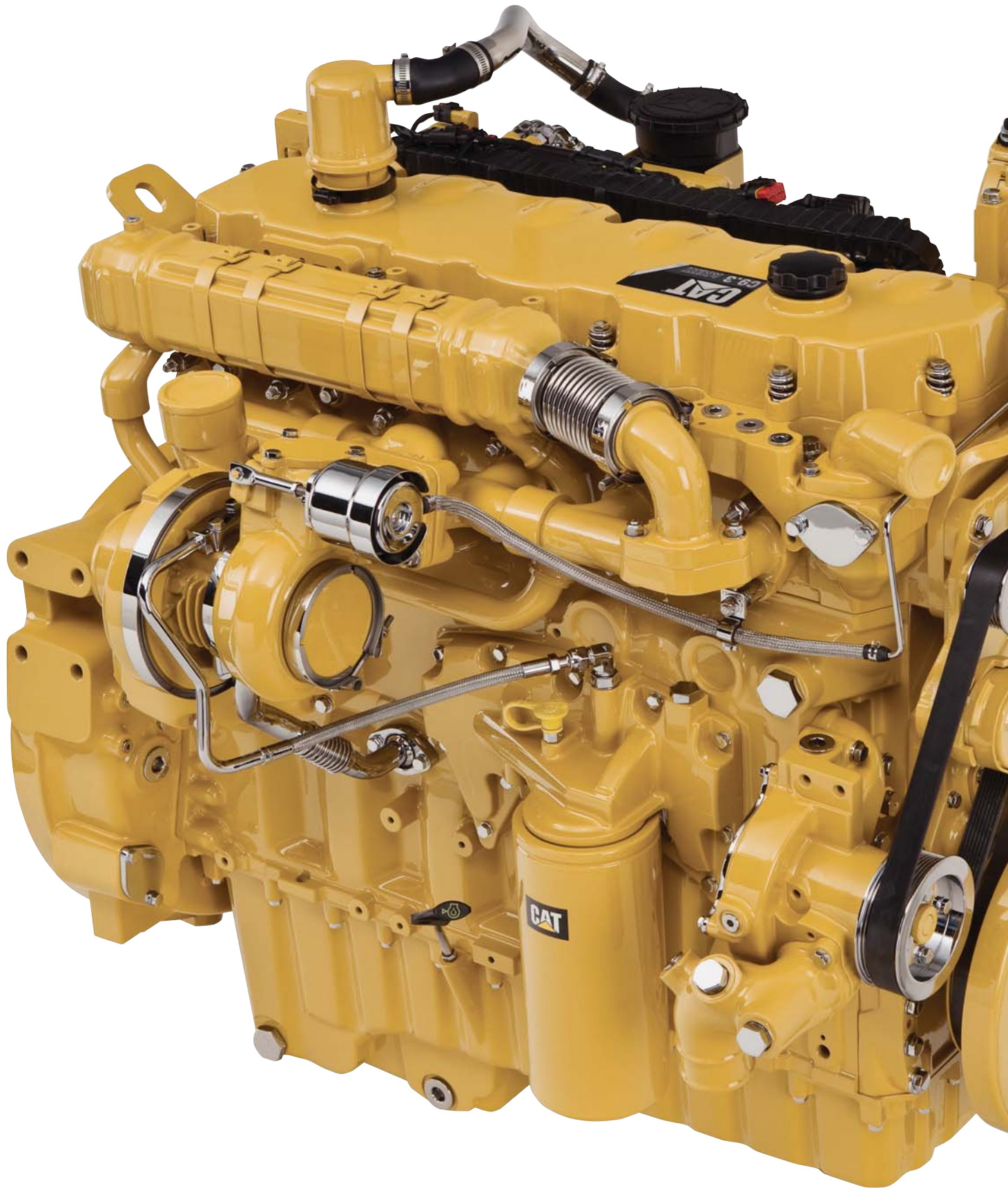





### **An Emissions Solution That Works**

The Cat C9.3 ACERT U.S. EPA Tier 4 Final engine is built to meet your demanding needs all day long. There is no interruption to your job process because the Cat regeneration system works automatically with no operator intervention required. If your operators are working in heat-restricted areas, they can use a manual override button to move the machine before the regeneration process begins.

### **Fuel Savers That Add Up**

The 336F XE features three power modes to help manage fuel consumption: high power, standard power, and economy. Two additional fuel-saving features are on-demand engine power and engine idle shutdown. On-demand engine power keeps speed low during light loading and idling; it automatically adjusts speed up when it senses a heavier load. Engine idle shutdown automatically shuts the engine off when idling for more than a specified amount of time that you set, which can save significant amounts of fuel and reduce emissions.

### **Biodiesel Not A Problem**

The 336F XE runs on ultra low sulfur diesel fuel, but you have added flexibility with the C9.3 ACERT engine because it's equipped to run on biodiesel up to B20 blended with ultra-low-sulfur diesel fuel. Just fill it up and go.

### **Proven Technology**

Every Tier 4 Final ACERT engine is equipped with a combination of proven electronic, fuel, air, and aftertreatment components. Applying these time-tested technologies lets us meet your high expectations for productivity, fuel efficiency, reliability, and service life. Following are the results you can expect:

- **High performance** across a variety of applications.
- **Enhanced reliability** through commonality and simplicity of design.
- **Maximized uptime and reduced cost** with world-class Cat dealer support.
- **Minimized impact of emission systems** – with no operator interaction required.
- **Durability** with long service life.
- **Improved fuel efficiency** with minimized maintenance costs.
- **Same great power** and response.





### **Comfortable Seat Options**

Not only is the cab as quiet as today's top pickup trucks, but several seat options help give you all the comfort you need for a long day of work. Air suspension, heated and air cooled seats are available; all include a reclining back, upper and lower seat slide adjustments, and height and tilt angle adjustments.

## **Operator Station**

Quiet and comfortable to keep you productive all day long.

### **A Safe, Quiet Cab**

The ROPS cab provides you with a safe working environment. It also contributes to your comfort because it's attached to a reinforced frame with special viscous mounts that limit vibration and unnecessary sound. Add in special roof lining and sealing and you have a cab that's as quiet inside as any of today's top pickup trucks.

### **Controls Just For You**

Not only can the right and left joystick consoles be physically adjusted to improve your comfort and productivity during the course of a day, but joystick lever gain and swing braking can also be adjusted – right through the monitor. Gain is the relationship between the control lever stroke and cylinder speed, and you can set it for either a quick or normal response. Swing braking can be set for either medium or slow response.

Other operator benefits include a pattern control changer accessible through the monitor instead of a lever beneath the floor and a heavy lift mode to increase system pressure – a nice benefit in situations requiring more controlled power.

### **A Helpful Monitor**

The LCD monitor is easy to see and navigate. Programmable in up to 42 languages to meet today's diverse workforce, the monitor clearly displays critical information you need to operate efficiently and effectively. Plus it projects the image from the standard rearview camera to help you see what's going on around you so you can stay safely focused on the job at hand.

### **Ample Storage & Auxiliary Power**

Storage spaces are conveniently located in the front, rear, and side consoles of the machine. A drink holder accommodates a large mug, and the shelf behind the seat stores large lunch or tool boxes. Two 12-volt power supply sockets are located near key storage areas so you can charge your phone or other electronic devices.

### **A Cool & Warm Environment**

The automatic climate control system features multiple air outlets with filtered ventilation. Air flows on the floor, behind the seat, and in front of you to make your work in either hot or cold weather much more pleasant and productive.



# Structures & Undercarriage

Built for your demanding applications.



## Robust Frame

You can expect excellent quality, reliability, and durability with the 336F XE. The machine's lower and upper are built to handle a hard day's work over and over again.

## Durable Undercarriage

Long undercarriage supports any type of work required from a 36-ton machine. Heavy-duty track rollers, precision forged carrier rollers, press-fit pin master joints, and enhanced track shoe bolts enhance machine durability and reduce the risk of downtime and your need to replace components. A three-piece guiding guard helps maintain track alignment and will improve your machine's overall performance.

## Great Weight

Whether you are loading trucks or picking pipe, the 336F XE has plenty of stability. Two counterweight options – standard and heavy – are available to meet your specific job requirements, and both come with integrated lifting eyes so they can be easily removed for maintenance or shipping.



# Attachments

Tools to make you productive and profitable.



## Get The Most Out Of One Machine

You can easily expand the performance of your machine by utilizing any of the variety of attachments offered by Cat Work Tools.

## Change Jobs Quickly

A quick coupler brings the ability to quickly change attachments and switch from job to job. The Cat Pin Grabber coupler is the secure way to decrease downtime and increase job site flexibility and overall productivity. Available tool control remembers pressures and flows for up to 10 tools. Simply toggle through the monitor, select the tool, and go to work for maximum efficiency.

## Dig, Finish & Compact

A wide range of buckets dig everything from top soil to harsh, abrasive material. For finishing and grading work, compact and shallow ditch cleaning buckets fit the need. A Cat compactor prepares the area for the next phase of construction.

## Break, Demolish & Scrap

A hydraulic hammer equips your machine for breaking rock and prepping trenches. A multi-processor, pulverizer, and shear take your machine into demolition jobs and help process debris for reuse and recycle.

## Move & Handle

Add a thumb and you have the ability to move and handle brush, rocks, and debris. For constant material handling, a grapple is your solution. Choose from three different styles for picking, sorting, and loading trash, demolition debris, or recyclables.

## Set Up Your Machine For Profitability

Your Cat dealer can install hydraulic kits to properly operate all Cat Work Tool attachments – maximizing the machine's uptime and your profits. All Cat Work Tool attachments are supported by the same Cat dealer network as your Cat machine.



**GRAB, SORT, LOAD**



**Pro Series Hydraulic Thumbs**



**Stiff Link Thumbs**



**Demolition & Sorting Grapple**



**Contractors' Grapples**



**Trash Grapples**

**SWAP TOOLS**



**Center-Lock™ Pin Grabber Coupler**

**DIG & PACK**



**Ditch Cleaning and Tilt Buckets**



**General Duty Buckets**



**Heavy Duty Buckets**



**Severe Duty Buckets**



**Extreme Duty Buckets**



**Vibratory Plate Compactors**

**CUT, CRUSH, BREAK & RIP**



**Multi-Processors**



**Scrap & Demolition Shears**



**Secondary Pulverizers**



**Hydraulic Hammers**



**Rippers**



# Front Linkage

Options for your far-reaching or up-close work.

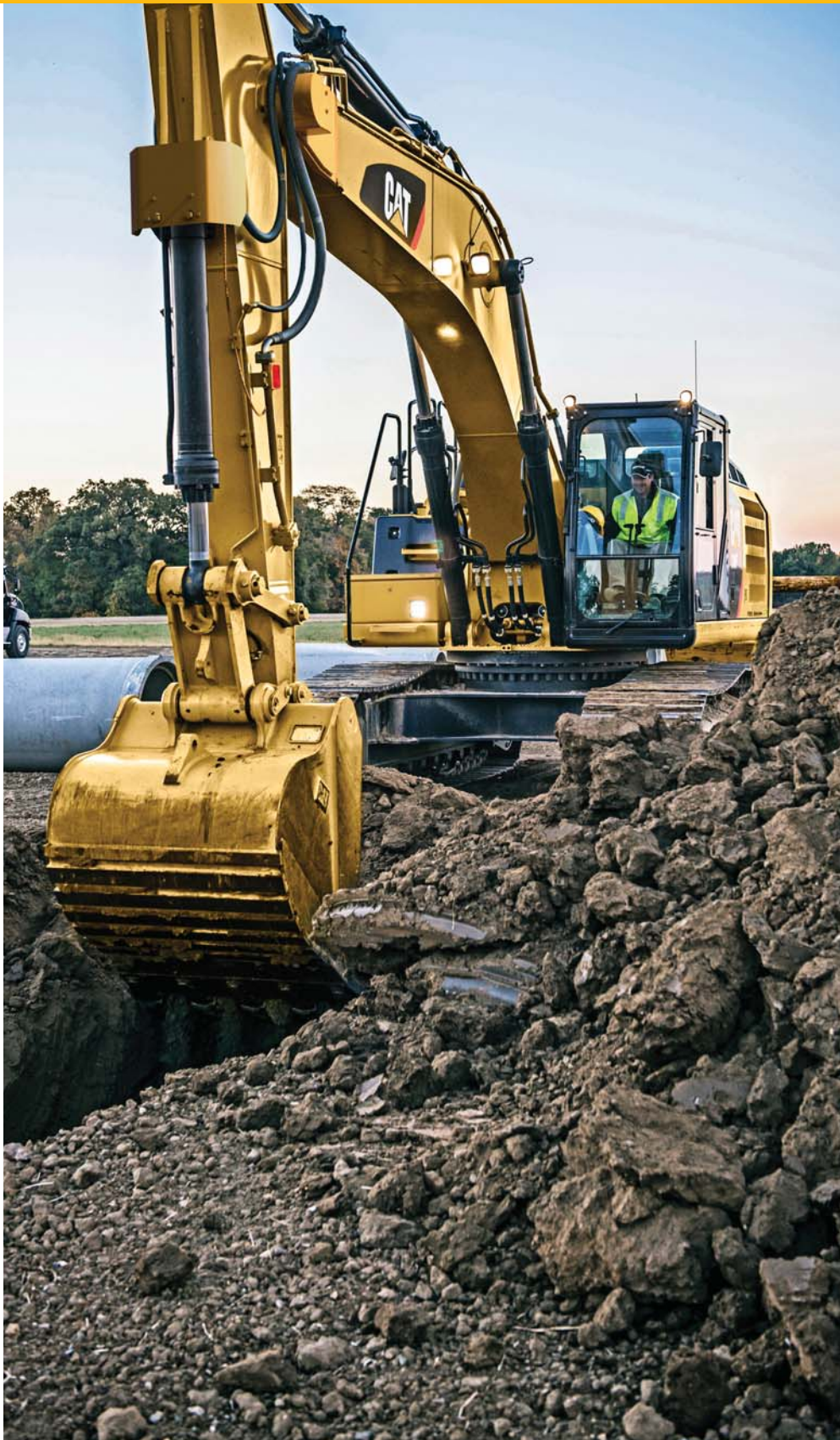

## Built To Last

Your uptime and service intervals are increased with high-quality, durable, and reliable booms, sticks, and linkage pins. Each boom and stick is built with internal baffle plates for additional durability, and each undergoes ultrasound inspection to ensure quality and reliability for the tough work you do.

## Two Types Available

Two types of booms and sticks are offered: heavy-duty (HD) reach and mass excavation (ME). HD reach booms and sticks offer you excellent all-around versatility for general excavation work like multipurpose digging and loading. ME booms and sticks offer you enhanced performance in heavy-duty material. They provide higher digging forces due to special boom and stick geometry, and bucket linkage and cylinders are built for greater durability.

Sticks are matched to the boom. Longer sticks are better for when you need to dig deep or load trucks. Shorter sticks provide greater breakout force and increase your productivity when using hydromechanical work tools.

Talk to your Cat dealer to pick the best front linkage for your applications.



# Serviceability

Designed to make your maintenance quick and easy.

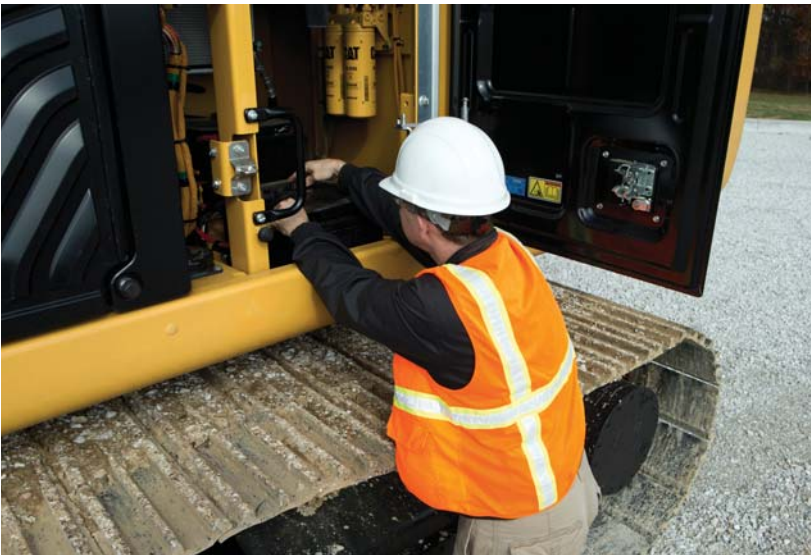

## Ground-Level Access

You can reach most routine maintenance items like fuel and oil filters, fluid taps, and grease points from the safety and convenience of ground level. Compartments feature wide service doors designed to help prevent debris entry, and they also securely latch in place to help make your service work simpler.

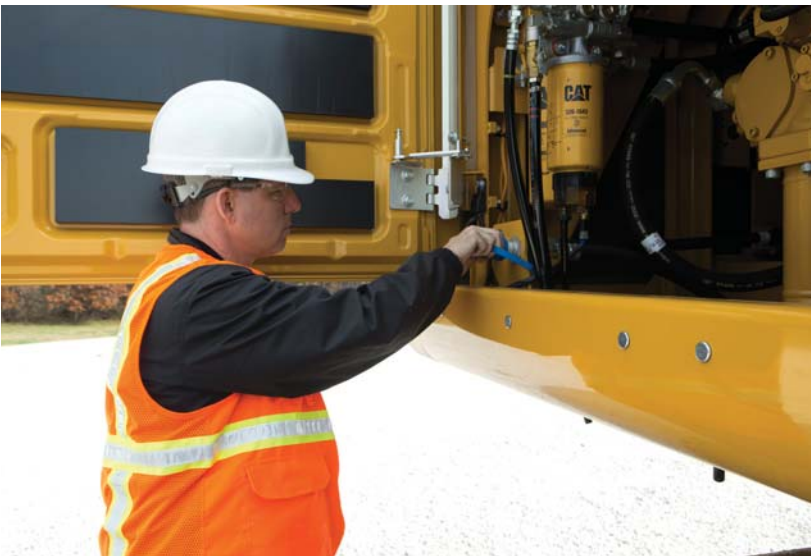

## A Smart Design

The high-ambient cooling system features a fuel-saving variable-speed fan and a side-by-side-mounted radiator and oil and air coolers for easy cleaning. Wider clearance between the two make blowing off debris easy for you, which can help improve your machine's reliability and performance.

## A Fresh Idea

When you select ventilation inside the cab, outside air enters through the fresh air filter. The filter is conveniently located on the side of the cab to make it easy to reach and replace, and it is protected by a lockable door that can be opened with the engine key.



## More Service Benefits

The fuel tank's drain tube makes it easy and simple for you to remove water and sediment during routine maintenance. Plus an integrated fuel level indicator pops up to help you reduce the possibility of fuel tank overfilling.



# Safety

Features to help protect you, day in and day out.

## A Safe, Quiet Cab

The Roll-Over Protective Structure (ROPS) cab provides you with a safe working environment. It also contributes to your comfort because it's attached to a reinforced frame with special viscous mounts that limit vibration and unnecessary sound. Add in special roof lining and sealing and you have a cab that's as quiet inside as any of today's top pickup trucks.

## Secure Contact Points

Multiple large steps get you into the cab as well as a leg up to the compartments. Extended hand and guard rails allow you to safely climb to the upper deck. Anti-skid plates reduce your slipping hazards in all types of weather conditions, and they can be removed for cleaning.

## Great Views

Ample glass gives you excellent visibility out front and to the side, and the standard rearview camera gives you a clear field of view behind the machine through the cab monitor. The available split-configuration windshield features an upper window with handles that make it easy to slide and store above you and a lower window that can be removed and stored on the inside wall of the cab. The large skylight also serves as an emergency exit and provides you with enhanced overhead visibility.

## Smart Lighting

Halogen lights provide plenty of illumination, and the cab and boom lights can be programmed to stay on for up to 90 seconds after the engine has been turned off to help you safely exit the machine. Optional High Intensity Discharge (HID) lights are available for enhanced night-time visibility.

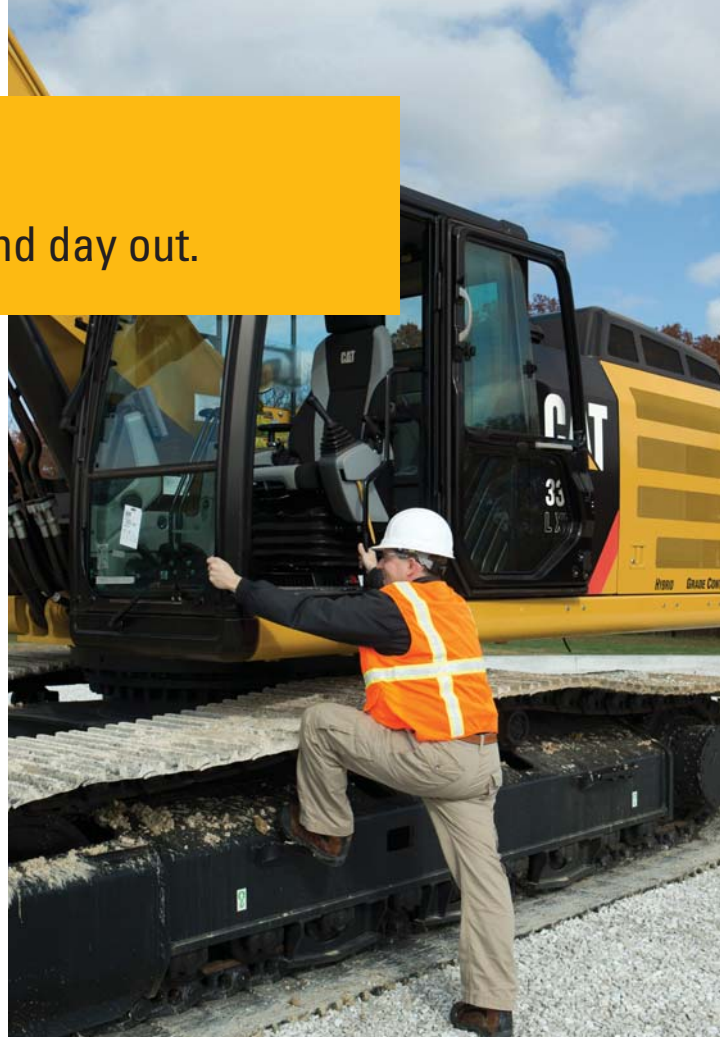

# Complete Customer Care

Your Cat dealer will support you like no other.



## Worldwide Parts Availability

Cat dealers utilize a worldwide parts network to maximize your machines' uptime. Plus they can help you save money with Cat remanufactured components.

## Advice You Can Trust

What are the job requirements and machine attachments? What production is needed? Your Cat dealer can provide recommendations to help you make the right machine choices.

## Financial Options Just For You

Consider financing options and day-to-day operating costs. Look at dealer services that can be included in the machine's cost to yield lower owning and operating costs over time.

## Support Agreements To Fit Your Needs

Cat dealers offer a variety of customer support agreements and work with you to develop a plan to meet your specific needs. These plans can cover the entire machine, including attachments, to help protect your investment.

## Operating Techniques To Boost Your Profits

Improving operating techniques can boost your profits. Your Cat dealer has videos, literature, and other ideas to help you increase productivity. Caterpillar also offers simulators and certified operator training to help maximize the return on your investment.

## What's Best For You Today... And Tomorrow

Repair, rebuild, or replace? Your Cat dealer can help you evaluate the cost involved so you can make the best choice for your business.



- The 336F XE moves as much material as a standard 336F yet burns up to 20% less fuel. This means more efficiency and productivity for you with less resource consumption.
- The 336F XE has the flexibility of running on either ultra-low-sulfur diesel fuel with 15 ppm of sulfur or less or biodiesel fuel up to B20 blended with ultra-low-sulfur diesel fuel.
- An overfill indicator rises when the tank is full to help your service technicians avoid spilling.
- You can ensure fast, easy, and secure changing of engine and hydraulic oil with the Cat QuickEvac™ system.
- A unique engine oil filter eliminates the need for painted metal cans and aluminum top plates. The cartridge-style spin-on housing enables the internal filter to be separated and replaced; the used internal element can be incinerated to help reduce waste.

## Sustainability

Generations ahead in every way.



# 336F XE Hydraulic Excavator Specifications

## Engine

Engine Model	Cat C9.3 ACERT	
Net Power – SAE J1349	226 kW	303 hp
Gross Power – SAE J1995	239 kW	321 hp
Bore	115 mm	4.53 in
Stroke	149 mm	5.87 in
Displacement	9.3 L	568 in <sup>3</sup>

## Weights

Minimum Operating Weight	37 100 kg	81,800 lb
Maximum Operating Weight	40 300 kg	88,800 lb

## Hydraulic System

Main System – Maximum Flow (Total)	570 L/min	151 gal/min
Swing System – Maximum Flow	276 L/min	73 gal/min
Maximum Pressure – Equipment		
Heavy Lift	37 000 kPa	5,366 psi
Normal	35 000 kPa	5,076 psi
Maximum Pressure – Travel	35 000 kPa	5,076 psi
Maximum Pressure – Swing	31 500 kPa	4,569 psi
Pilot System – Maximum Flow	28 L/min	7 gal/min
Pilot System – Maximum Pressure	4100 kPa	595 psi
Boom Cylinder – Bore	150 mm	5.9 in
Boom Cylinder – Stroke	1440 mm	56.7 in
Stick Cylinder – Bore	170 mm	6.7 in
Stick Cylinder – Stroke	1738 mm	68.4 in
DB Bucket Cylinder – Bore	150 mm	5.9 in
DB Bucket Cylinder – Stroke	1151 mm	45.3 in

## Drive

Maximum Travel Speed	4.8 km/h	3 mph
Maximum Drawbar Pull	294 kN	66,093 lbf

## Swing Mechanism

Swing Speed	8.7 rpm	
Swing Torque	109 kN·m	80,144 lbf·ft

## Service Refill Capacities

Fuel Tank Capacity	620 L	164 gal
Cooling System	43 L	11 gal
Engine Oil (with filter)	32 L	8 gal
Swing Drive (each)	19 L	5 gal
Final Drive (each)	8 L	2 gal
Hydraulic System (including tank)	380 L	100 gal
Hydraulic Tank	175 L	46 gal
Diesel Exhaust Fluid (DEF) Tank*	41 L	11 gal

\*DEF must meet ISO 22241.

## Sound Performance

Operator Noise – ISO 6396	73 dB(A)
Spectator Noise – ISO 6395	105 dB(A)

## Standards

Brakes	ISO 10265 2008
Cab/FOGS	ISO 10262 1998
Cab/ROPS	ISO 12117 2008



# 336F XE Hydraulic Excavator Specifications

## Dimensions

All dimensions are approximate.

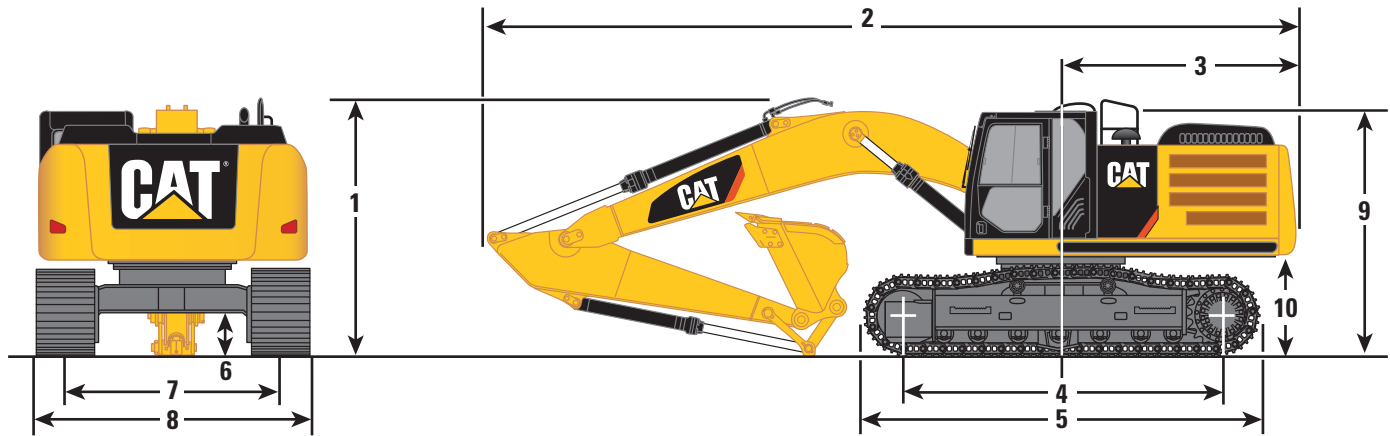

Boom Options	HD Reach Boom 6.50 m (21'4")				Mass Boom 6.18 m (20'3")	
Stick Options	R3.9DB	12'10"	R3.2DB	10'6"	M2.55TB	8'4"
<b>1</b> Shipping Height including Shoe Lug Height	3660 mm	12'0"	3510 mm	11'6"	3600 mm	11'10"
<b>2</b> Shipping Length	11 200 mm	36'9"	11 190 mm	36'9"	10 890 mm	35'9"
<b>3</b> Tail Swing Radius	3490 mm	11'5"	3490 mm	11'5"	3470 mm	11'5"
<b>4</b> Length to Center of Rollers						
Long Undercarriage	4040 mm	13'3"	4040 mm	13'3"	4040 mm	13'3"
<b>5</b> Track Length						
Long Undercarriage	5030 mm	16'6"	5030 mm	16'6"	5030 mm	16'6"
<b>6</b> Ground Clearance including Shoe Lug Height	510 mm	1'8"	510 mm	1'8"	510 mm	1'8"
Ground Clearance without Shoe Lug Height	480 mm	1'7"	480 mm	1'7"	480 mm	1'7"
<b>7</b> Track Gauge						
Long Undercarriage	2590 mm	8'6"	2590 mm	8'6"	2590 mm	8'6"
<b>8</b> Transport Width						
Long Undercarriage – 700 mm (28") Triple Grouser Shoes	3290 mm	10'10"	3290 mm	10'10"	3290 mm	10'10"
Long Undercarriage – 800 mm (32") Triple Grouser Shoes	3390 mm	11'1"	3390 mm	11'1"	3390 mm	11'1"
Long Undercarriage – 850 mm (34") Triple Grouser Shoes	3440 mm	11'3"	3440 mm	11'3"	3440 mm	11'3"
<b>9</b> Cab Height	3150 mm	10'4"	3150 mm	10'4"	3150 mm	10'4"
Cab Height with Top Guard	3360 mm	11'0"	3360 mm	11'0"	3360 mm	11'0"
<b>10</b> Counterweight Clearance without Shoe Lug Height	1220 mm	4'0"	1220 mm	4'0"	1220 mm	4'0"
<b>Buckets</b>						
Type	DB1536GP-C	DB1536GP-C	DB1536GP-C	DB1536GP-C	TB1676SD	
Part Number	342-2192	342-2192	342-2192	342-2192	339-3748	
Capacity – SAE	2.28 m <sup>3</sup>	2.98 yd <sup>3</sup>	2.28 m <sup>3</sup>	2.98 yd <sup>3</sup>	2.41 m <sup>3</sup>	3.15 yd <sup>3</sup>
Tip Radius	1753 mm	5'9"	1753 mm	5'9"	1895 mm	6'2"

# 336F XE Hydraulic Excavator Specifications

## Working Ranges

All dimensions are approximate.

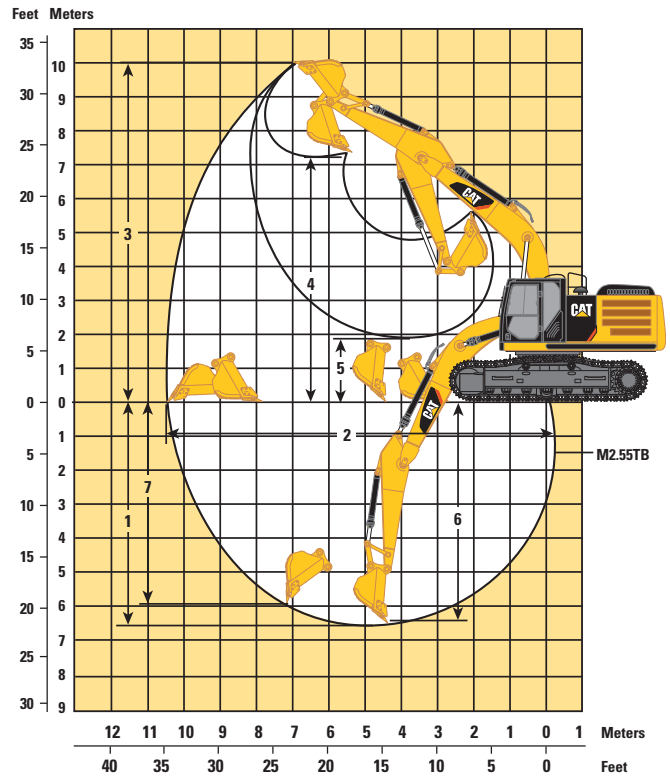
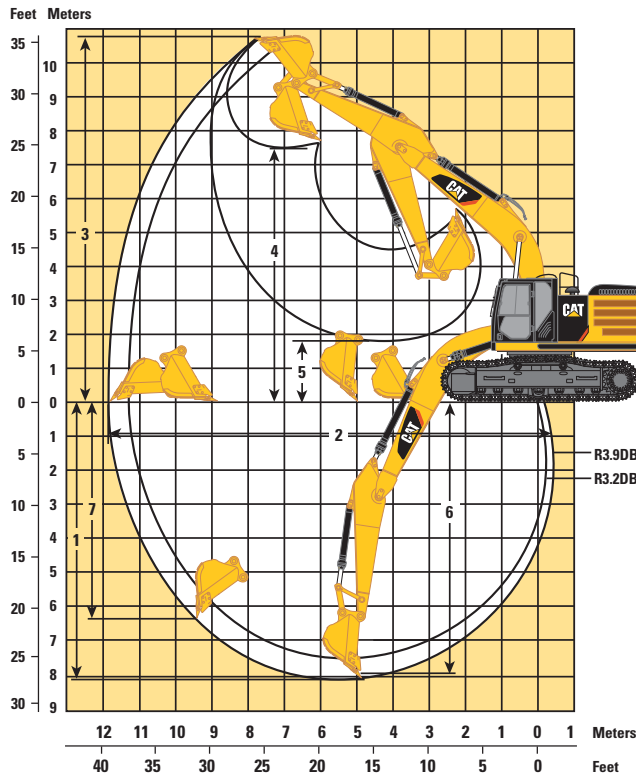

### Boom Options

#### HD Reach Boom 6.50 m (21'4")

#### Mass Boom 6.18 m (20'3")

### Stick Options

	R3.9DB	12'10"	R3.2DB	10'6"	M2.55TB	8'4"
<b>1</b> Maximum Digging Depth	8190 mm	26'10"	7490 mm	24'7"	6650 mm	21'10"
<b>2</b> Maximum Reach at Ground Level	11 720 mm	38'5"	11 020 mm	36'2"	10 260 mm	33'8"
<b>3</b> Maximum Cutting Height	10 740 mm	35'3"	10 320 mm	33'10"	9970 mm	32'9"
<b>4</b> Maximum Loading Height	7500 mm	24'7"	7110 mm	23'4"	6620 mm	21'9"
<b>5</b> Minimum Loading Height	1910 mm	6'3"	2610 mm	8'7"	2920 mm	9'7"
<b>6</b> Maximum Depth Cut for 2440 mm (8'0") Level Bottom	7610 mm	25'0"	6820 mm	22'5"	5810 mm	19'1"
<b>7</b> Maximum Vertical Wall Digging Depth	6310 mm	20'8"	5500 mm	18'1"	4450 mm	14'7"

### Buckets

Type	DB1536GP-C		DB1536GP-C		TB1676SD	
Part Number	342-2192		342-2192		339-3748	
Capacity – SAE	2.28 m <sup>3</sup>	2.98 yd <sup>3</sup>	2.28 m <sup>3</sup>	2.98 yd <sup>3</sup>	2.41 m <sup>3</sup>	3.15 yd <sup>3</sup>
Tip Radius	1753 mm	5'9"	1753 mm	5'9"	1895 mm	6'2"



# 336F XE Hydraulic Excavator Specifications

## Major Component Weights\*

Lower Structure (without counterweight and track)		
Long Undercarriage	8900 kg	19,600 lb
Upper Structure (without front linkage)		
	10 800 kg	23,800 lb
Counterweight 5.1 mt (5.6 t)	5100 kg	11,200 lb
Counterweight 6.1 mt (6.7 t)	6100 kg	13,400 lb
Boom (includes lines, pins and stick cylinder)		
HD Reach Boom – 6.50 m (21'4")	4100 kg	9,000 lb
Mass Boom – 6.18 m (20'3")	4200 kg	9,300 lb
Stick (includes lines, pins and bucket cylinder)		
R3.9DB HD (12'10")	1900 kg	4,200 lb
R3.2DB HD (10'6")	1800 kg	4,000 lb
M2.55TB (8'4")	2100 kg	4,600 lb
Track Shoe (Long)		
700 mm (28") Triple Grouser	4300 kg	9,500 lb
800 mm (32") Triple Grouser	5100 kg	11,200 lb
850 mm (34") Triple Grouser	5400 kg	11,900 lb
Quick Coupler	600 kg	1,300 lb
Bucket		
DB1536GP-C 342-2192 SAE 2.28 m <sup>3</sup> (2.98 yd <sup>3</sup> )	1500 kg	3,300 lb

\*Base machine includes 75 kg (165 lb) operator weight and 90% fuel weight, and undercarriage with center guard.

## Operating Weight and Ground Pressure

	700 mm (28") Triple Grouser Shoes				800 mm (32") Triple Grouser Shoes				850 mm (34") Triple Grouser Shoes			
	kg	lb	kPa	psi	kg	lb	kPa	psi	kg	lb	kPa	psi
HD Reach Boom – 6.50 m (21'4")												
R3.9DB (12'10")	36 600	80,700	58.4	8.5	37 200	82,000	52.0	7.5	37 500	82,700	49.3	7.2
R3.2DB (10'6")	36 400	80,200	58.1	8.4	37 100	81,800	51.8	7.5	37 400	82,500	49.2	7.1
Mass Boom – 6.18 m (20'3")												
M2.55TB (8'4")	37 800	83,300	60.4	8.8	39 800	87,700	55.6	8.1	40 100	88,400	52.7	7.6

# 336F XE Hydraulic Excavator Specifications

## Bucket and Stick Forces

Boom Options	HD Reach Boom 6.50 m (21'4")				Mass Boom 6.18 m (20'3")	
	R3.9DB	12'10"	R3.2DB	10'6"	M2.55TB	8'4"
<b>Stick Options</b>						
General Duty						
Bucket Digging Force (SAE)	188.5 kN	42,380 lbf	188.5 kN	42,380 lbf	234.7 kN	52,760 lbf
Stick Digging Force (SAE)	141.5 kN	31,810 lbf	162.1 kN	36,440 lbf	184.6 kN	41,500 lbf
Heavy Duty						
Bucket Digging Force (SAE)	184.9 kN	41,570 lbf	184.9 kN	41,570 lbf	234.7 kN	52,760 lbf
Stick Digging Force (SAE)	140.7 kN	31,630 lbf	161.1 kN	36,220 lbf	184.6 kN	41,500 lbf
Severe Duty						
Bucket Digging Force (SAE)	184.9 kN	41,570 lbf	184.9 kN	41,570 lbf	231.0 kN	51,930 lbf
Stick Digging Force (SAE)	140.7 kN	31,630 lbf	161.1 kN	36,220 lbf	183.9 kN	41,340 lbf
Extreme Duty						
Bucket Digging Force (SAE)	184.9 kN	41,570 lbf	184.9 kN	41,570 lbf	—	—
Stick Digging Force (SAE)	140.7 kN	31,630 lbf	161.1 kN	36,220 lbf	—	—









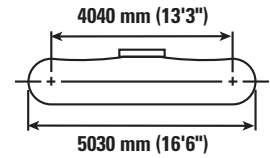
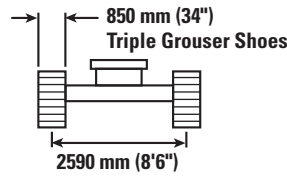
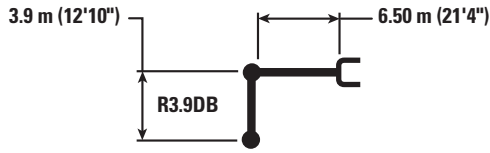





Caterpillar recommends using appropriate work tools to maximize the value customers receive from our products. Use of work tools, including buckets, which are outside of Caterpillar's recommendations or specifications for weight, dimensions, flows, pressures, etc. may result in less-than-optimal performance, including but not limited to reductions in production, stability, reliability, and component durability. Improper use of a work tool resulting in sweeping, prying, twisting and/or catching of heavy loads will reduce the life of the boom and stick.



# 336F XE Hydraulic Excavator Specifications

## HD Reach Boom Lift Capacities – Counterweight: 5.1 mt (5.6 t) – Heavy Lift: On



		1.5 m/5.0 ft		3.0 m/10.0 ft		4.5 m/15.0 ft		6.0 m/20.0 ft		7.5 m/25.0 ft		9.0 m/30.0 ft				m ft
																
9.0 m 30.0 ft	kg lb													*6050 *13,450	*6050 *13,450	7.35 24.17
7.5 m 25.0 ft	kg lb									*7450 *16,450	*7450 *16,450			*5650 *12,450	*5650 *12,450	8.54 28.33
6.0 m 20.0 ft	kg lb									*7750 *16,950	7600 16,350	*7300 *14,050	5600 11,950	*5450 *12,050	5250 11,600	9.34 30.83
4.5 m 15.0 ft	kg lb							*9450 *20,500	*9450 *20,500	*8500 *18,450	7350 15,850	*7900 *17,300	5500 11,750	*5500 *12,050	4700 10,350	9.84 32.50
3.0 m 10.0 ft	kg lb					*14 800 *31,850	*14 800 *31,850	*11 200 *24,250	9800 21,100	*9400 *20,450	7050 15,150	8350 17,950	5300 11,400	*5650 *12,450	4400 9,700	10.10 33.30
1.5 m 5.0 ft	kg lb					*17 850 *38,500	13 850 29,850	*12 900 *27,850	9200 19,850	*10 350 *22,500	6700 14,450	8150 17,550	5150 11,050	*6000 *13,150	4300 9,450	10.13 33.30
0.0 m 0.0 ft	kg lb			*8250 *18,800	*8250 *18,800	*19 450 *42,050	13 200 28,400	*14 050 *30,400	8800 18,900	10 450 22,450	6450 13,900	8000 17,200	5000 10,750	*6550 *14,400	4350 9,550	9.93 32.50
-1.5 m -5.0 ft	kg lb	*8650 *19,300	*8650 *19,300	*12 900 *29,200	*12 900 *29,200	*19 700 *42,650	12 950 27,850	14 400 30,900	8550 18,450	10 300 22,100	6300 13,550	7900 17,050	4900 10,600	7350 16,250	4600 10,100	9.49 31.67
-3.0 m -10.0 ft	kg lb	*13 700 *30,600	*13 700 *30,600	*18 850 *42,600	*18 850 *42,600	*18 850 *40,800	12 950 27,900	*14 150 *30,550	8500 18,350	10 250 22,050	6250 13,500			8250 18,250	5150 11,350	8.77 29.17
-4.5 m -15.0 ft	kg lb	*19 600 *44,100	*19 600 *44,100	*23 250 *50,200	*23 250 *50,200	*16 800 *36,200	13 200 28,350	*12 750 *27,350	8650 18,600	*9550 *20,150	6400 13,850			*9150 *20,100	6200 13,850	7.69 25.00
-6.0 m -20.0 ft	kg lb					*12 800 *26,950	*12 800 *26,950	*9050 *20,000	9050					*8900 *19,500	*8900 *19,500	6.06 20.00



ISO 10567











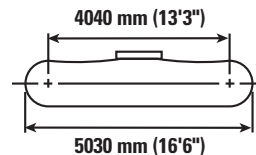
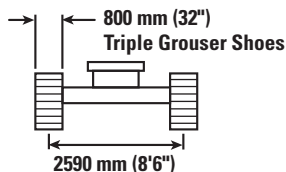
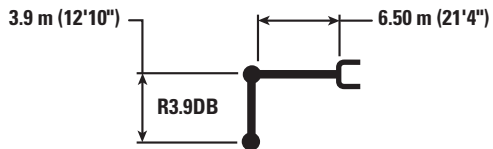







\*Indicates that the load is limited by hydraulic lifting capacity rather than tipping load. The above loads are in compliance with hydraulic excavator lift capacity standard ISO 10567:2007. They do not exceed 87% of hydraulic lifting capacity or 75% of tipping load. Weight of all lifting accessories must be deducted from the above lifting capacities. Lifting capacities are based on the machine standing on a firm, uniform supporting surface. The use of a work tool attachment point to handle/lift objects, could affect the machine lift performance.

Always refer to the appropriate Operation and Maintenance Manual for specific product information.

# 336F XE Hydraulic Excavator Specifications

## HD Reach Boom Lift Capacities – Counterweight: 5.1 mt (5.6 t) – Heavy Lift: On



		1.5 m/5.0 ft		3.0 m/10.0 ft		4.5 m/15.0 ft		6.0 m/20.0 ft		7.5 m/25.0 ft		9.0 m/30.0 ft				m ft
																
9.0 m 30.0 ft	kg lb													*6050 *13,450	*6050 *13,450	7.35 24.17
7.5 m 25.0 ft	kg lb									*7450 *16,450	*7450 *16,450			*5650 *12,450	*5650 *12,450	8.54 28.33
6.0 m 20.0 ft	kg lb									*7750 *16,950	7550 16,250	*7300 *14,050	5550 11,850	*5450 *12,050	5200 11,500	9.34 30.83
4.5 m 15.0 ft	kg lb							*9450 *20,500	*9450 *20,500	*8500 *18,450	7300 15,700	*7900 *17,300	5450 11,650	*5500 *12,050	4650 10,300	9.84 32.50
3.0 m 10.0 ft	kg lb					*14 800 *31,850	*14 800 *31,850	*11 200 *24,250	9700 20,950	*9400 *20,450	7000 15,050	8300 17,800	5300 11,350	*5650 *12,450	4350 9,600	10.10 33.33
1.5 m 5.0 ft	kg lb					*17 850 *38,500	13 750 29,600	*12 900 *27,850	9150 19,700	*10 350 *22,500	6650 14,350	8100 17,400	5100 10,950	*6000 *13,150	4250 9,350	10.13 33.33
0.0 m 0.0 ft	kg lb			*8250 *18,800	*8250 *18,800	*19 450 *42,050	13 100 28,200	*14 050 *30,400	8700 18,750	10 350 22,300	6400 13,800	7950 17,050	4950 10,650	*6550 *14,400	4300 9,450	9.93 32.50
-1.5 m -5.0 ft	kg lb	*8650 *19,300	*8650 *19,300	*12 900 *29,200	*12 900 *29,200	*19 700 *42,650	12 850 27,650	14 300 30,650	8500 18,300	10 200 21,950	6250 13,450	7850 16,900	4900 10,500	7300 16,100	4550 10,000	9.49 31.67
-3.0 m -10.0 ft	kg lb	*13 700 *30,600	*13 700 *30,600	*18 850 *42,600	*18 850 *42,600	*18 850 *40,800	12 850 27,650	*14 150 30,550	8450 18,200	10 150 21,850	6200 13,400			8200 18,100	5100 11,250	8.77 29.17
-4.5 m -15.0 ft	kg lb	*19 600 *44,100	*19 600 *44,100	*23 250 *50,200	*23 250 *50,200	*16 800 *36,200	13 100 28,150	*12 750 *27,350	8550 18,500	*9550 *20,150	6350 13,750			*9150 *20,100	6150 13,750	7.69 25.00
-6.0 m -20.0 ft	kg lb					*12 800 *26,950	*12 800 *26,950	*9050	9000					*8900 *19,500	8850 *19,500	6.06 20.00



ISO 10567



\*Indicates that the load is limited by hydraulic lifting capacity rather than tipping load. The above loads are in compliance with hydraulic excavator lift capacity standard ISO 10567:2007. They do not exceed 87% of hydraulic lifting capacity or 75% of tipping load. Weight of all lifting accessories must be deducted from the above lifting capacities. Lifting capacities are based on the machine standing on a firm, uniform supporting surface. The use of a work tool attachment point to handle/lift objects, could affect the machine lift performance.

Always refer to the appropriate Operation and Maintenance Manual for specific product information.



# 336F XE Hydraulic Excavator Specifications

## HD Reach Boom Lift Capacities – Counterweight: 5.1 mt (5.6 t) – Heavy Lift: On

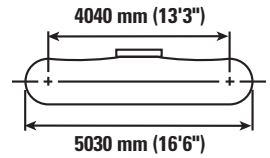
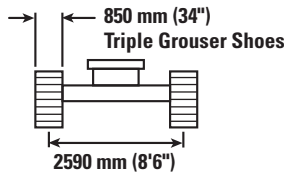
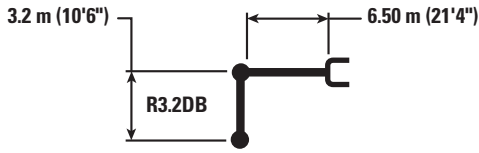

		3.0 m/10.0 ft		4.5 m/15.0 ft		6.0 m/20.0 ft		7.5 m/25.0 ft		9.0 m/30.0 ft		m ft		
7.5 m 25.0 ft	kg lb							*8500 18,850	7550 16,100			*7200 *15,900	*7200 *15,900	7.70 25.00
6.0 m 20.0 ft	kg lb							*8600 *18,850	7500 16,100			*7000 *15,400	5950 13,250	8.58 28.33
4.5 m 15.0 ft	kg lb			*13 100	*13 100	*10 550 *22,800	10 200 22,000	*9250 *20,150	7250 15,650	*8250	5450	*7050 *15,500	5300 11,700	9.13 30.00
3.0 m 10.0 ft	kg lb			*16 600 *35,600	14 550 31,350	*12 200 *26,350	9600 20,750	*10 100 *21,900	6950 15,000	8300 17,900	5300 11,400	*7300 *16,100	4950 10,900	9.41 30.83
1.5 m 5.0 ft	kg lb			*19 050 *41,150	13 600 29,300	*13 650 *29,500	9100 19,650	10 700 23,000	6700 14,400	8150 17,550	5150 11,100	7600 16,750	4800 10,600	9.44 31.67
0.0 m 0.0 ft	kg lb			*19 900 *43,100	13 200 28,350	*14 500 *31,350	8800 18,950	10 450 22,550	6500 13,950	8050 17,350	5050 10,900	7800 17,150	4900 10,750	9.22 30.83
-1.5 m -5.0 ft	kg lb	*14 100 *31,900	*14 100 *31,900	*19 500 *42,300	13 100 28,150	14 450 31,100	8650 18,600	10 350 22,300	6400 13,750			8350 18,450	5250 11,550	8.75 29.17
-3.0 m -10.0 ft	kg lb	*22 200 *50,300	*22 200 *50,300	*18 100 *39,150	13 200 28,400	*13 800 *29,800	8700 18,700	10 400 22,450	6450 13,900			9600 21,250	6000 13,250	7.96 26.67
-4.5 m -15.0 ft	kg lb	*20 350 *43,800	*20 350 *43,800	*15 350 *32,950	13 500 29,100	*11 650 *24,750	8900 19,200					*9800 *21,600	7650 17,100	6.75 22.50



ISO 10567



\*Indicates that the load is limited by hydraulic lifting capacity rather than tipping load. The above loads are in compliance with hydraulic excavator lift capacity standard ISO 10567:2007. They do not exceed 87% of hydraulic lifting capacity or 75% of tipping load. Weight of all lifting accessories must be deducted from the above lifting capacities. Lifting capacities are based on the machine standing on a firm, uniform supporting surface. The use of a work tool attachment point to handle/lift objects, could affect the machine lift performance.

Always refer to the appropriate Operation and Maintenance Manual for specific product information.

# 336F XE Hydraulic Excavator Specifications

## HD Reach Boom Lift Capacities – Counterweight: 5.1 mt (5.6 t) – Heavy Lift: On

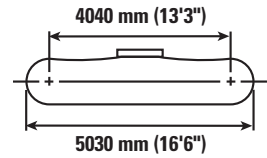
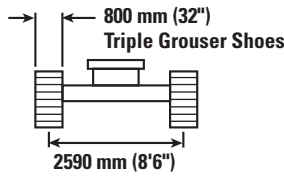
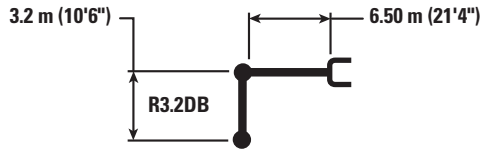

		3.0 m/10.0 ft		4.5 m/15.0 ft		6.0 m/20.0 ft		7.5 m/25.0 ft		9.0 m/30.0 ft		m ft		
7.5 m 25.0 ft	kg lb							*8500 7500				*7200 *15,900	7150 *15,900	7.70 25.00
6.0 m 20.0 ft	kg lb							*8600 *18,850	7450 16,000			*7000 *15,400	5950 13,150	8.58 28.33
4.5 m 15.0 ft	kg lb			*13 100	*13 100	*10 550 *22,800	10 150 21,850	*9250 *20,150	7200 15,500	*8250	5400	*7050 *15,500	5250 11,600	9.13 30.00
3.0 m 10.0 ft	kg lb			*16 600 *35,600	14 450 31,150	*12 200 *26,350	9550 20,600	*10 100 *21,900	6900 14,900	8250 17,750	5250 11,300	*7300 *16,100	4900 10,800	9.41 30.83
1.5 m 5.0 ft	kg lb			*19 050 *41,150	13 500 29,050	*13 650 *29,500	9050 19,500	10 600 22,850	6650 14,300	8100 17,450	5100 11,000	7550 16,650	4750 10,500	9.44 31.67
0.0 m 0.0 ft	kg lb			*19 900 *43,100	13 100 28,150	*14 500 31,200	8700 18,800	10 400 22,350	6450 13,850	8000 17,200	5000 10,800	7750 17,000	4850 10,700	9.22 30.83
-1.5 m -5.0 ft	kg lb	*14 100 *31,900	*14 100 *31,900	*19 500 *42,300	13 000 27,950	14 350 30,850	8600 18,500	10 300 22,150	6350 13,650			8300 18,300	5200 11,450	8.75 29.17
-3.0 m -10.0 ft	kg lb	*22 200 *50,300	*22 200 *50,300	*18 100 *39,150	13 100 28,200	*13 800 *29,800	8600 18,550	10 350 22,250	6400 13,800			9550 21,100	5950 13,150	7.96 26.67
-4.5 m -15.0 ft	kg lb	*20 350 *43,800	*20 350 *43,800	*15 350 *32,950	13 400 28,900	*11 650 *24,750	8850 19,050					*9800 *21,600	7600 16,950	6.75 22.50



ISO 10567



\*Indicates that the load is limited by hydraulic lifting capacity rather than tipping load. The above loads are in compliance with hydraulic excavator lift capacity standard ISO 10567:2007. They do not exceed 87% of hydraulic lifting capacity or 75% of tipping load. Weight of all lifting accessories must be deducted from the above lifting capacities. Lifting capacities are based on the machine standing on a firm, uniform supporting surface. The use of a work tool attachment point to handle/lift objects, could affect the machine lift performance.







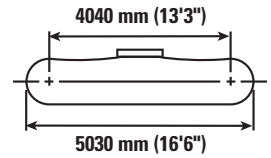
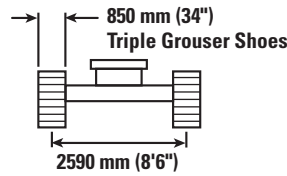
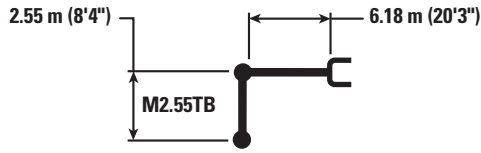

Always refer to the appropriate Operation and Maintenance Manual for specific product information.



# 336F XE Hydraulic Excavator Specifications

## Mass Boom Lift Capacities – Counterweight: 6.1 mt (6.7 t) – Heavy Lift: On



		3.0 m/10.0 ft		4.5 m/15.0 ft		6.0 m/20.0 ft		7.5 m/25.0 ft				m ft
												
7.5 m 25.0 ft	kg lb					*9850 *21,800	*9850 *21,800			*8850 *19,550	*8850 *19,550	6.58 21.67
6.0 m 20.0 ft	kg lb					*10 200 *22,250	*10 200 *22,250	*9650	7800	*8400 *18,550	7650 17,050	7.60 25.00
4.5 m 15.0 ft	kg lb			*14 250 *30,600	*14 250 *30,600	*11 350 *24,550	10 750 23,200	*9950 *21,700	7650 16,450	*8400 *18,500	6600 14,650	8.21 27.50
3.0 m 10.0 ft	kg lb			*17 400 *37,450	15 350 33,150	*12 750 *27,600	10 200 22,000	*10 550 *22,950	7400 15,900	*8750 *19,200	6100 13,450	8.52 28.33
1.5 m 5.0 ft	kg lb			*19 350 *41,800	14 550 31,300	*13 950 *30,150	9750 21,000	*11 150 *24,200	7150 15,400	*9400 *20,650	5950 13,100	8.55 28.33
0.0 m 0.0 ft	kg lb			*19 550 *42,400	14 250 30,650	*14 450 *31,250	9450 20,400	11 200 24,150	7000 15,100	9700 21,350	6100 13,450	8.31 27.50
-1.5 m -5.0 ft	kg lb	*17 900 *40,600	*17 900 *40,600	*18 600 *40,300	14 250 30,700	*14 050 *30,450	9400 20,250	*10 900 *23,400	7000 15,050	*10 300 *22,700	6700 14,750	7.78 25.83
-3.0 m -10.0 ft	kg lb	*21 300 *46,200	*21 300 *46,200	*16 400 *35,450	14 500 31,200	*12 500 *26,800	9550 20,600			*10 300 *22,700	8000 17,750	6.88 22.50
-4.5 m -15.0 ft	kg lb			*12 050 *25,450	*12 050 *25,450					*9550 *20,850	*9550 *20,850	5.43 17.50



ISO 10567











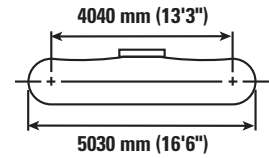
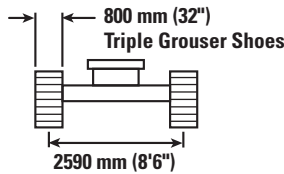
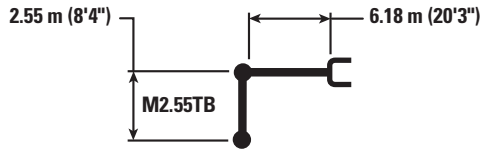



\*Indicates that the load is limited by hydraulic lifting capacity rather than tipping load. The above loads are in compliance with hydraulic excavator lift capacity standard ISO 10567:2007. They do not exceed 87% of hydraulic lifting capacity or 75% of tipping load. Weight of all lifting accessories must be deducted from the above lifting capacities. Lifting capacities are based on the machine standing on a firm, uniform supporting surface. The use of a work tool attachment point to handle/lift objects, could affect the machine lift performance.

Always refer to the appropriate Operation and Maintenance Manual for specific product information.

# 336F XE Hydraulic Excavator Specifications

## Mass Boom Lift Capacities – Counterweight: 6.1 mt (6.7 t) – Heavy Lift: On



		3.0 m/10.0 ft		4.5 m/15.0 ft		6.0 m/20.0 ft		7.5 m/25.0 ft				
												m ft
7.5 m 25.0 ft	kg lb					*9850 *21,800	*9850 *21,800			*8850 *19,550	*8850 *19,550	6.58 21.67
6.0 m 20.0 ft	kg lb					*10 200 *22,250	*10 200 *22,250	*9650	7750	*8400 *18,550	7600 16,950	7.60 25.00
4.5 m 15.0 ft	kg lb			*14 250 *30,600	*14 250 *30,600	*11 350 *24,550	10 700 23,050	*9950 *21,700	7600 16,350	*8400 *18,500	6600 14,550	8.21 27.50
3.0 m 10.0 ft	kg lb			*17 400 *37,450	15 250 32,950	*12 750 *27,600	10 150 21,850	*10 550 *22,950	7350 15,800	*8750 *19,200	6050 13,400	8.52 28.33
1.5 m 5.0 ft	kg lb			*19 350 *41,800	14 450 31,100	*13 950 *30,150	9650 20,850	*11 150 *24,200	7100 15,300	9300 20,500	5900 13,000	8.55 28.33
0.0 m 0.0 ft	kg lb			*19 550 *42,400	14 150 30,450	*14 450 *31,250	9400 20,250	11 150 23,950	6950 14,950	9600 21,200	6050 13,350	8.31 27.50
-1.5 m -5.0 ft	kg lb	*17 900 *40,600	*17 900 *40,600	*18 600 *40,300	14 200 30,450	*14 050 *30,450	9350 20,100	*10 900 *23,400	6950 14,950	*10 300 *22,700	6650 14,600	7.78 25.83
-3.0 m -10.0 ft	kg lb	*21 300 *46,200	*21 300 *46,200	*16 400 *35,450	14 400 31,000	*12 500 *26,800	9500 20,450			*10 300 *22,700	7950 17,600	6.88 22.50
-4.5 m -15.0 ft	kg lb			*12 050 *25,450	*12 050 *25,450					*9550 *20,850	*9550 *20,850	5.43 17.50



ISO 10567



\*Indicates that the load is limited by hydraulic lifting capacity rather than tipping load. The above loads are in compliance with hydraulic excavator lift capacity standard ISO 10567:2007. They do not exceed 87% of hydraulic lifting capacity or 75% of tipping load. Weight of all lifting accessories must be deducted from the above lifting capacities. Lifting capacities are based on the machine standing on a firm, uniform supporting surface. The use of a work tool attachment point to handle/lift objects, could affect the machine lift performance.

Always refer to the appropriate Operation and Maintenance Manual for specific product information.



# 336F XE Hydraulic Excavator Specifications

## Work Tool Offering Guide\*

Boom Options	HD Reach Boom 6.50 m (21'4")		Mass Boom 6.18 m (20'3")
Stick Options	R3.9DB (12'10")	R3.2DB (10'6")	M2.55TB (8'4")
Counterweight	Heavy	Heavy	Standard
Hammers	H140Es H160Es	H140Es H160Es	H140Es H160Es
Multi-Processors	MP324 CC Jaw MP324 D Jaw MP324 P Jaw MP324 S Jaw MP324 TS Jaw MP324 U Jaw MP30 CC Jaw*** MP30 CR Jaw*** MP30 PP Jaw*** MP30 PS Jaw*** MP30 PS Jaw***	MP324 CC Jaw MP324 D Jaw MP324 P Jaw MP324 S Jaw MP324 TS Jaw MP324 U Jaw MP30 CC Jaw MP30 CR Jaw MP30 PP Jaw^,^^ MP30 PS Jaw MP30 S Jaw MP30 TS Jaw**	MP30 CC Jaw** MP30 CR Jaw** MP30 PP Jaw**^ MP30 PS Jaw** MP30 S Jaw** MP30 TS Jaw***
Pulverizers	P225 P235***	P225 P235	P235**
Demolition and Sorting Grapples	G325B-D/R G330^,^^	G325B-D/R G330	G330**
Scrap and Demolition Shears	S325B  S365C#	S325B S340B*** S365C#	S340B*** S365C#
Compactors (Vibratory Plate)	CVP110	CVP110	CVP110
Orange Peel Grapple			
Rippers			
Pin Grabber Coupler	Cat PG		
Dedicated Quick Coupler	CW-45 CW-45S		

These work tools are available for the 336F L XE.  
Consult your Cat dealer for proper match.

\*Offerings not available in all areas. Matches are dependent on excavator configurations. Consult your Cat dealer to determine what is offered in your area and for proper work tool match.

\*\*Match; Pin-on or CW coupler.

\*\*\*Match; Pin-on only.

#Match; Boom Mount.

^Work over the front only with CW coupler.

^^Work over the front only with Cat PG.

**Note:** Demolition and Sorting Grapples: D – Demolition shells, R – Recycling shells

# 336F XE Hydraulic Excavator Specifications

## Bucket Specifications and Compatibility

	Linkage	Width		Capacity		Weight		Fill	HD Reach Boom – 6.50 m (21'4")		ME Boom – 6.18 m (20'3")
		mm	in	m <sup>3</sup>	yd <sup>3</sup>	kg	lb		%	R3.2DB (10'6")	R3.9DB (12'10")
<b>Without Quick Coupler</b>											
General Duty (GDC)	DB	750	30	0.94	1.23	952	2,099	100%	●	●	
	DB	900	36	1.19	1.56	1040	2,292	100%	●	●	
	DB	1050	42	1.46	1.91	1147	2,528	100%	●	●	
	DB	1200	48	1.73	2.26	1232	2,716	100%	●	⊖	
	DB	1350	54	2.00	2.62	1342	2,957	100%	⊙	○	
	DB	1500	60	2.27	2.98	1451	3,197	100%	⊖	○	
	DB	1650	66	2.55	3.33	1536	3,386	100%	X	X	
Heavy Duty (HD)	DB	750	30	0.73	0.95	1031	2,273	100%	●	●	
	DB	900	36	0.95	1.24	1178	2,595	100%	●	●	
	DB	1050	42	1.17	1.54	1267	2,793	100%	●	●	
	DB	1200	48	1.40	1.84	1398	3,080	100%	●	⊙	
	DB	1350	54	1.64	2.14	1459	3,215	100%	●	⊖	
	DB	1500	60	1.88	2.46	1566	3,452	100%	⊙	○	
	DB	1650	66	2.12	2.77	1697	3,740	100%	X	X	
	DB	1800	72	2.36	3.08	1851	4,080	100%	X	X	
	TB	1800	72	2.69	3.52	2423	5,340	100%			⊖
Severe Duty (SD)	DB	750	30	0.73	0.95	1096	2,415	90%	●	●	
	DB	900	36	0.95	1.24	1252	2,760	90%	●	●	
	DB	1050	42	1.17	1.54	1353	2,981	90%	●	●	
	DB	1200	48	1.40	1.84	1493	3,292	90%	●	●	
	DB	1350	54	1.64	2.14	1599	3,524	90%	●	⊙	

### Maximum Material Density:

- 2100 kg/m<sup>3</sup> (3,500 lb/yd<sup>3</sup>)
- ⊙ 1800 kg/m<sup>3</sup> (3,000 lb/yd<sup>3</sup>)
- ⊖ 1500 kg/m<sup>3</sup> (2,500 lb/yd<sup>3</sup>)
- 1200 kg/m<sup>3</sup> (2,000 lb/yd<sup>3</sup>)
- ◇ 900 kg/m<sup>3</sup> (1,500 lb/yd<sup>3</sup>)
- X Not Recommended

The above loads are in compliance with hydraulic excavator standard EN474, they do not exceed 87% of hydraulic lifting capacity or 75% of tipping capacity with front linkage fully extended at ground line with bucket curled.

Capacity based on ISO 7451.

Bucket weight with General Duty tips.

Caterpillar recommends using appropriate work tools to maximize the value customers receive from our products. Use of work tools, including buckets, which are outside of Caterpillar's recommendations or specifications for weight, dimensions, flows, pressures, etc. may result in less-than-optimal performance, including but not limited to reductions in production, stability, reliability, and component durability. Improper use of a work tool resulting in sweeping, prying, twisting and/or catching of heavy loads will reduce the life of the boom and stick.



# 336F XE Hydraulic Excavator Specifications

## Bucket Specifications and Compatibility

	Linkage	Width		Capacity		Weight		Fill	HD Reach Boom – 6.50 m (21'4")		ME Boom – 6.18 m (20'3")
		mm	in	m <sup>3</sup>	yd <sup>3</sup>	kg	lb		%	R3.2DB (10'6")	R3.9DB (12'10")
<b>With Quick Coupler</b>											
General Duty (GDC)	DB	750	30	0.94	1.23	952	2,099	100%	●	●	
	DB	900	36	1.19	1.56	1040	2,292	100%	●	●	
	DB	1050	42	1.46	1.91	1147	2,528	100%	●	⊖	
	DB	1200	48	1.73	2.26	1232	2,716	100%	⊙	○	
	DB	1350	54	2.00	2.62	1342	2,957	100%	⊖	◇	
	DB	1500	60	2.27	2.98	1451	3,197	100%	○	◇	
	DB	1650	66	2.55	3.33	1536	3,386	100%	X	X	
Heavy Duty (HD)	DB	750	30	0.73	0.95	1031	2,273	100%	●	●	
	DB	900	36	0.95	1.24	1178	2,595	100%	●	●	
	DB	1050	42	1.17	1.54	1267	2,793	100%	●	⊙	
	DB	1200	48	1.40	1.84	1398	3,080	100%	●	⊖	
	DB	1350	54	1.64	2.14	1459	3,215	100%	⊖	○	
	DB	1500	60	1.88	2.46	1566	3,452	100%	⊖	◇	
	DB	1650	66	2.12	2.77	1697	3,740	100%	X	X	
	DB	1800	72	2.36	3.08	1851	4,080	100%	X	X	
	TB	1800	72	2.69	3.52	2423	5,340	100%			○
Severe Duty (SD)	DB	750	30	0.73	0.95	1096	2,415	90%	●	●	
	DB	900	36	0.95	1.24	1252	2,760	90%	●	●	
	DB	1050	42	1.17	1.54	1353	2,981	90%	●	●	
	DB	1200	48	1.40	1.84	1493	3,292	90%	●	⊖	
	DB	1350	54	1.64	2.14	1599	3,524	90%	⊙	○	

### Maximum Material Density:

- 2100 kg/m<sup>3</sup> (3,500 lb/yd<sup>3</sup>)
- ⊙ 1800 kg/m<sup>3</sup> (3,000 lb/yd<sup>3</sup>)
- ⊖ 1500 kg/m<sup>3</sup> (2,500 lb/yd<sup>3</sup>)
- 1200 kg/m<sup>3</sup> (2,000 lb/yd<sup>3</sup>)
- ◇ 900 kg/m<sup>3</sup> (1,500 lb/yd<sup>3</sup>)
- X Not Recommended

The above loads are in compliance with hydraulic excavator standard EN474, they do not exceed 87% of hydraulic lifting capacity or 75% of tipping capacity with front linkage fully extended at ground line with bucket curled.

Capacity based on ISO 7451.

Bucket weight with General Duty tips.

Caterpillar recommends using appropriate work tools to maximize the value customers receive from our products. Use of work tools, including buckets, which are outside of Caterpillar's recommendations or specifications for weight, dimensions, flows, pressures, etc. may result in less-than-optimal performance, including but not limited to reductions in production, stability, reliability, and component durability. Improper use of a work tool resulting in sweeping, prying, twisting and/or catching of heavy loads will reduce the life of the boom and stick.

## Standard Equipment

Standard equipment may vary. Consult your Cat dealer for details.

### CAB

- Pressurized operator station with positive filtration
- Mirror package
- Sliding upper door window
- Glass-breaking safety hammer
- Removable lower windshield with in-cab storage bracket
- Coat hook
- Beverage holder
- Literature holder
- Radio with MP3 auxiliary audio port
- Two stereo speakers
- Storage shelf for lunch or toolbox
- Color LCD monitor
- Adjustable armrest
- Height-adjustable joystick consoles
- Neutral lever for all controls
- Travel control pedals with removable hand levers
- Two power outlets, 10 amp (total)
- Laminated glass front upper window
- Tempered glass lower front, side, and rear windows
- Cab hatch emergency exit
- Sunscreen
- Windshield wiper, lower with washer
- AM/FM radio
- Air pre-filter
- Travel alarm
- Straight travel pedal

### ELECTRICAL

- 80 amp alternator
- Circuit breaker

### ENGINE

- C9.3 ACERT diesel engine
- Biodiesel capable
- Meets Tier 4 Final emission standards
- 2300 m (7,500 ft) altitude capability
- Electric priming pump
- Automatic engine speed control
- Standard, economy and high power modes
- Two-speed travel
- Side-by-side cooling system
- Radial seal air filter
- Primary filter with water separator and water separator indicator switch
- Fuel differential indicator switch in fuel line
- 2×4 micron main filters and 1×10 micron primary filter in fuel line
- Water level indicator for water separator
- Starting kit, cold weather, -32° C (-26° F)
- Jump start receptacle
- Engine and hydraulic oil quick drains

### FRONT LINKAGE

- DB bucket linkage with lifting eye
- HD 6.50 m (21'4") reach boom with left- and right-side light

### HYDRAULIC SYSTEM

- Automatic swing parking brake
- Joystick control pattern change through monitor
- High-performance hydraulic return filter

### LIGHTS

- Cab-mounted working light with time delay
- Halogen boom and cab lights with time delay
- Exterior lights integrated into storage box

### UNDERCARRIAGE

- Grease Lubricated Track (GLT2) with resin seal
- Towing eye on base frame
- Heavy-duty bottom guard
- Segmented (3 piece) track guiding guard
- Heavy-duty travel motor protection

### SECURITY

- Cat one key security system
- Door locks
- Cap locks on fuel and hydraulic tanks
- Lockable external tool/storage box
- Signaling/warning horn
- Secondary engine shutoff switch
- Openable skylight for emergency exit
- Rearview camera

### TECHNOLOGY

- Product Link
- Cat Production Measurement
- Cat Grade Control

## Optional Equipment

Optional equipment may vary. Consult your Cat dealer for details.

### FRONT LINKAGE

- HD 6.5 m (21'4") boom
- R3.9DB (12'10") stick
- R3.2DB (10'6") stick
- Mass 6.18 m (20'3") boom
- M2.55TB (8'4") stick

### COUNTERWEIGHT

- 5.1 mt (5.6 t)
- 6.1 mt (6.7 t)

### HYDRAULIC SYSTEM

- Additional circuit
- Boom and stick lines
- High-pressure line
- Cat quick coupler line – high- and medium-pressure capable
- Quick coupler for high pressure
- Tool control system

### UNDERCARRIAGE

- 700 mm (28") triple grouser shoes
- 800 mm (32") triple grouser shoes
- 850 mm (34") triple grouser shoes

### SECURITY

- Top and front operator protective guards



For more complete information on Cat products, dealer services, and industry solutions, visit us on the web at [www.cat.com](http://www.cat.com)

AEHQ7420 (05-2015)  
(North America)

© 2015 Caterpillar  
All rights reserved

Materials and specifications are subject to change without notice. Featured machines in photos may include additional equipment. See your Cat dealer for available options.

CAT, CATERPILLAR, SAFETY.CAT.COM, their respective logos, "Caterpillar Yellow" and the "Power Edge" trade dress, as well as corporate and product identity used herein, are trademarks of Caterpillar and may not be used without permission.

VisionLink is a trademark of Trimble Navigation Limited, registered in the United States and in other countries.

